

DIMENSIONS

TV1000 / TV1200

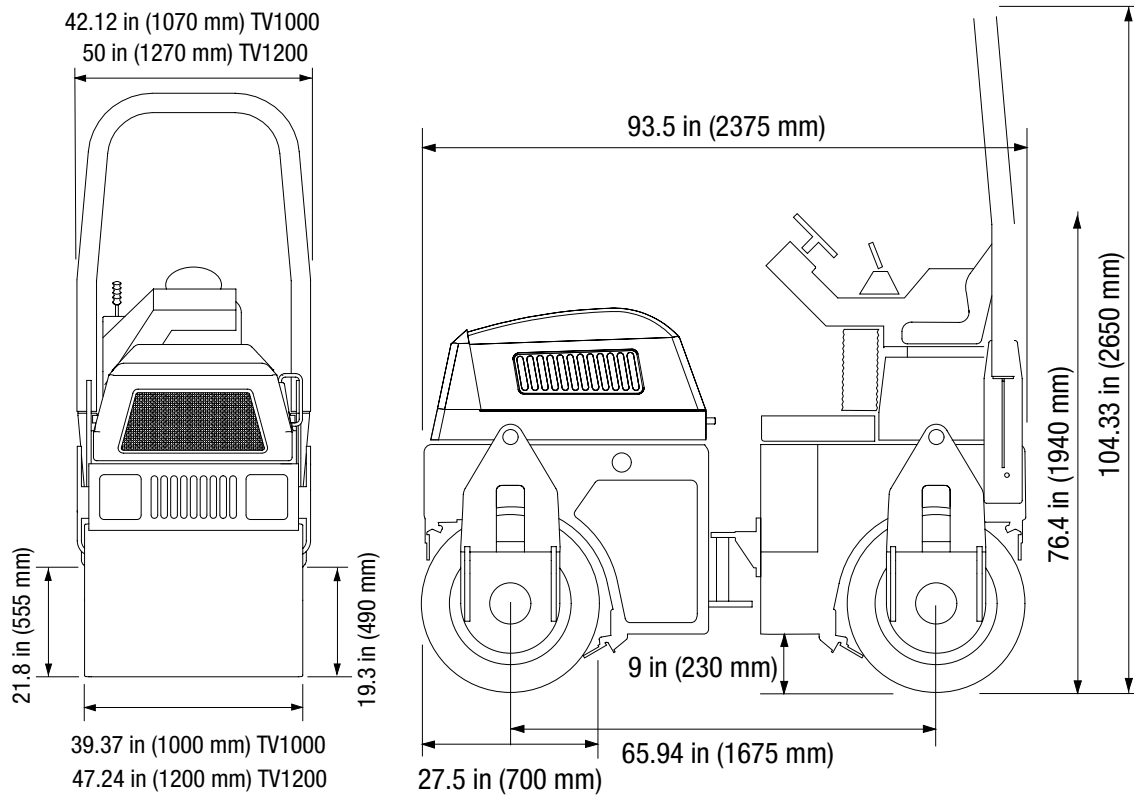

Dimensions

	TV1000	TV1200
Total Width	42.12 in (1,070 mm)	50 in (1,270 mm)
Total Length	93.5 in (2,375 mm)	
Total Height	104.33 in (2,650 mm)	

Standard Equipment

Vandal Protection Package	Back-up alarm
2 scraper bars per drum	Hydraulic test points
Tow valve	12 volt battery disconnect
Pressure and gravity water	ROPS
Electrical diagnostics system (LED lights)	

WORKS FOR YOU.™